

Kang Li \*, Sivagunalan Sivanathan, and Nigel Copner \*[kang.li@southwales.ac.uk](mailto:kang.li@southwales.ac.uk)

Faculty of Computing, Engineering and Science, University of South Wales, Pontypridd, CF37 1DL, United Kingdom

## Abstract

- The Four Wave Mixing (FWM)-FSI<sup>†</sup> system employs a tunable and stationary laser as signal light and pump source, respectively. Their interaction in the FWM module generates idler light sweeping simultaneously but oppositely to the signal light. The tuning range of the signal laser and conversion band of FWM is crucial to the accuracy of distance measurement.
- We present a dual sweep FSI system based on FWM in Si- nano waveguide (SOINW) and single-mode highly non-linear fibre (HNLF). The pump wavelength is set at 1546 nm, and the signal light sweeps from 1545 to 1523 nm. Distance estimation vs obtained samples on a vibrating target is discussed.

## Dual-Frequency Sweeping Light Source Based on SOINW

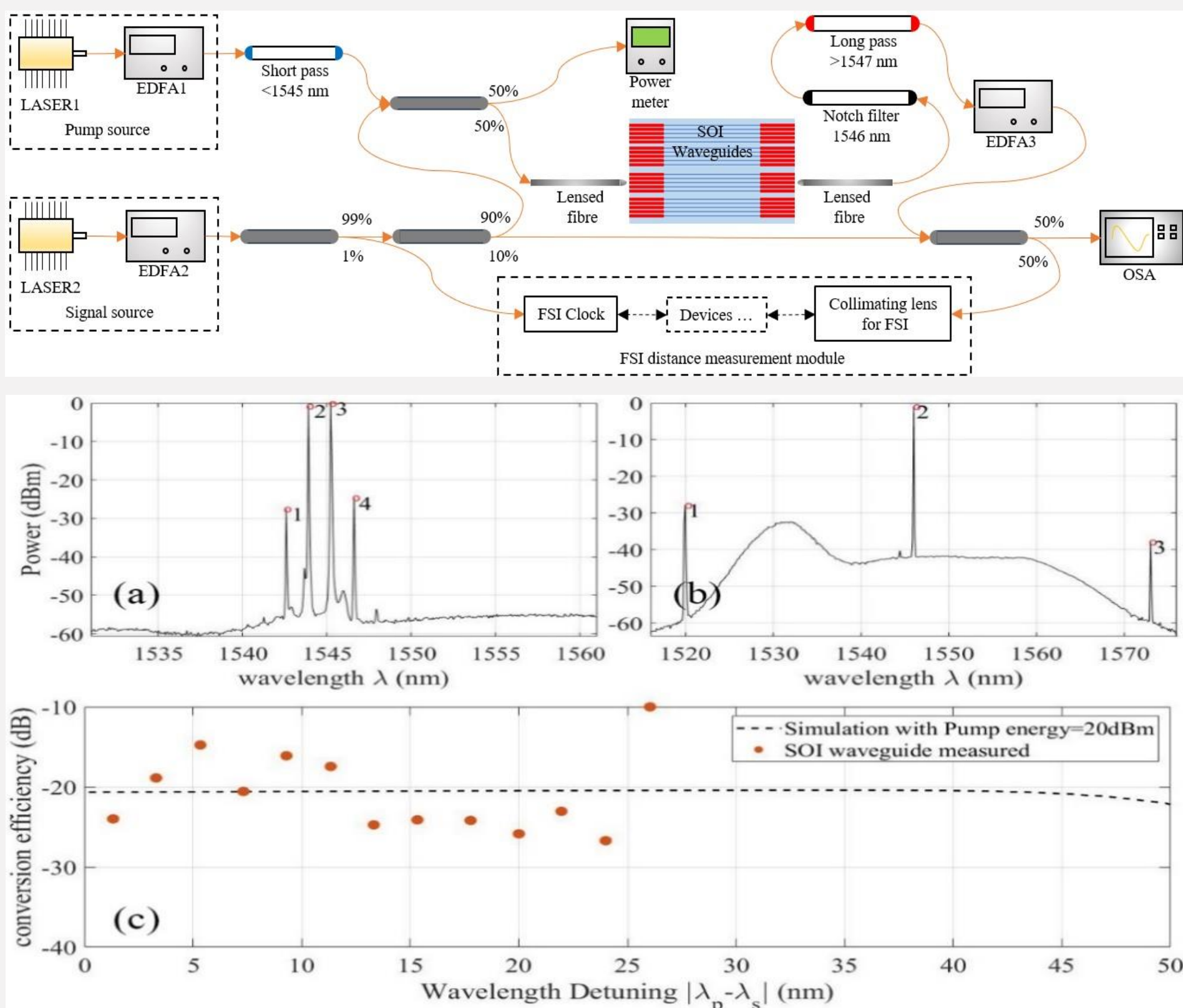

(a) the FWM spectrum at the smallest detuning point (1.32 nm) tested, where the peak 1,2,3 and 4 are converted pump, signal, Pump, and idler light respectively, (b) the FWM spectrum of at the largest detuning point (26.04 nm), where the peak 1,2, and 3 are signal, pump, and idler light respectively, the converted pump is out of the view since large detuning wavelength, (c) is the tested FWM conversion band of SOI.

## Dual-Frequency Sweeping Light Source Based on HNLF

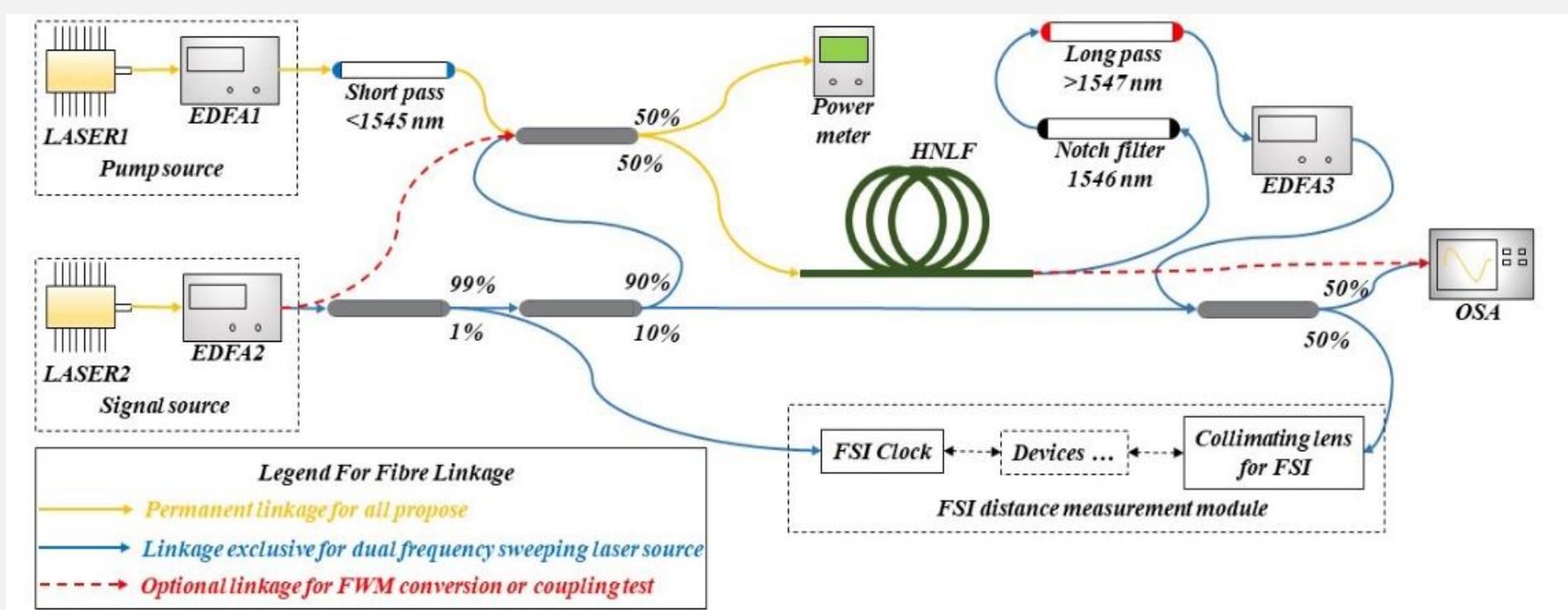

Block diagram of an experimental testing system for HNLF.

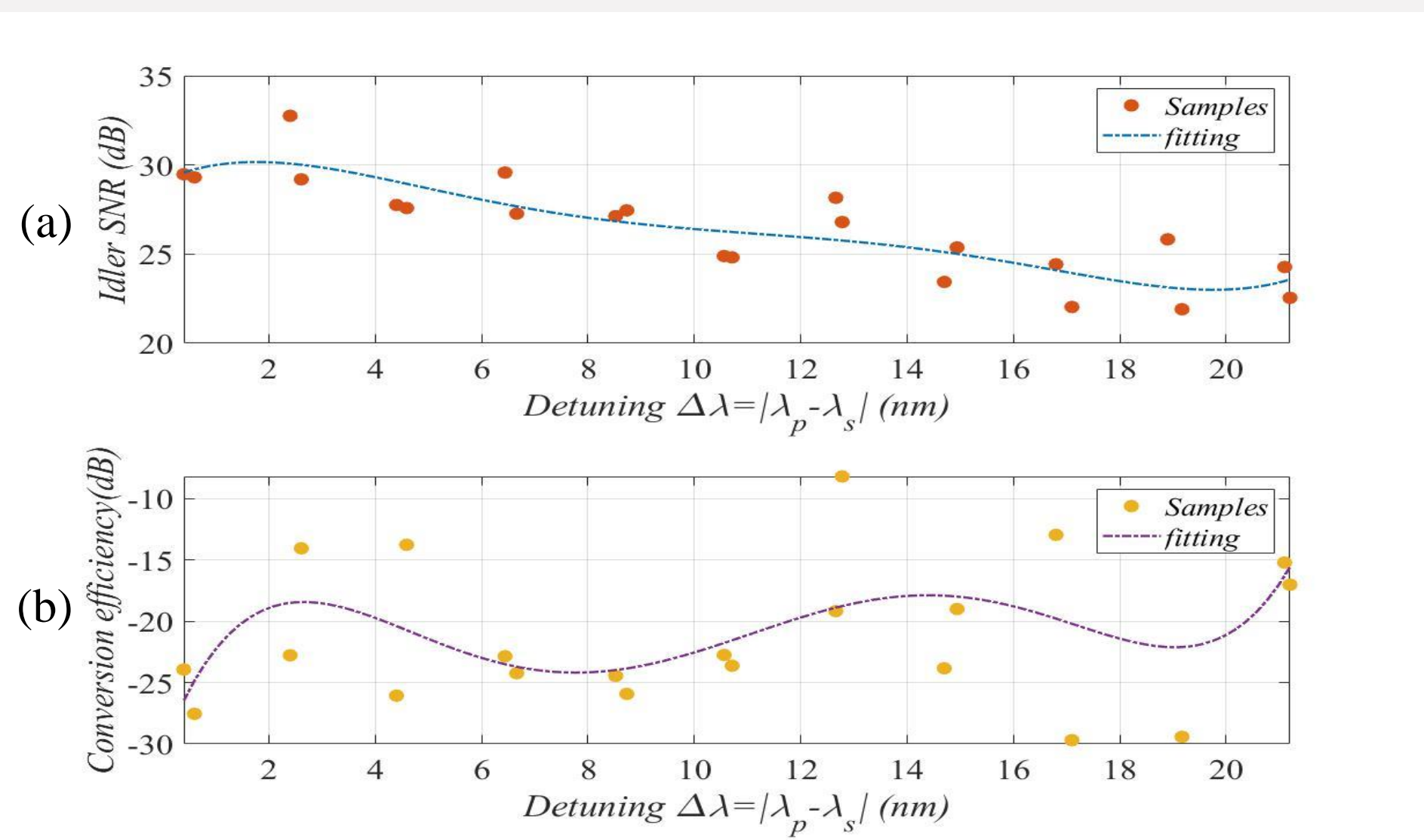

(a) The SNR of idler  $SNR_i$  versus wavelength detuning  $\Delta\lambda$ . (b) The conversion efficiency versus wavelength detuning  $\Delta\lambda$ .

## Schematic diagram to measure the performance of the Unit Under Test (HNLf and SOINW)

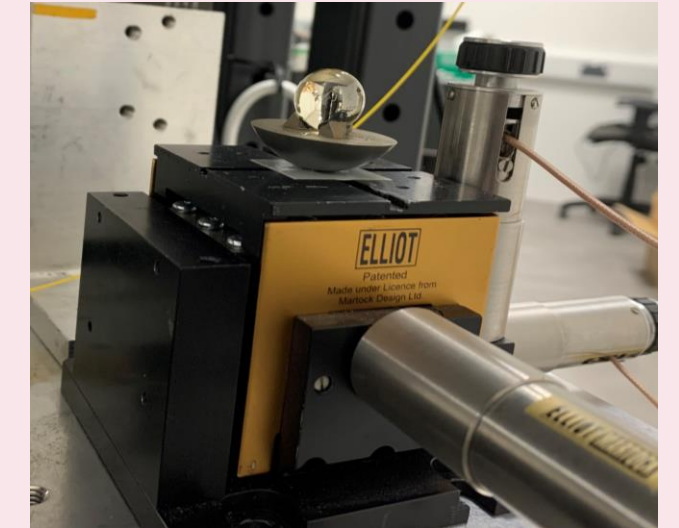
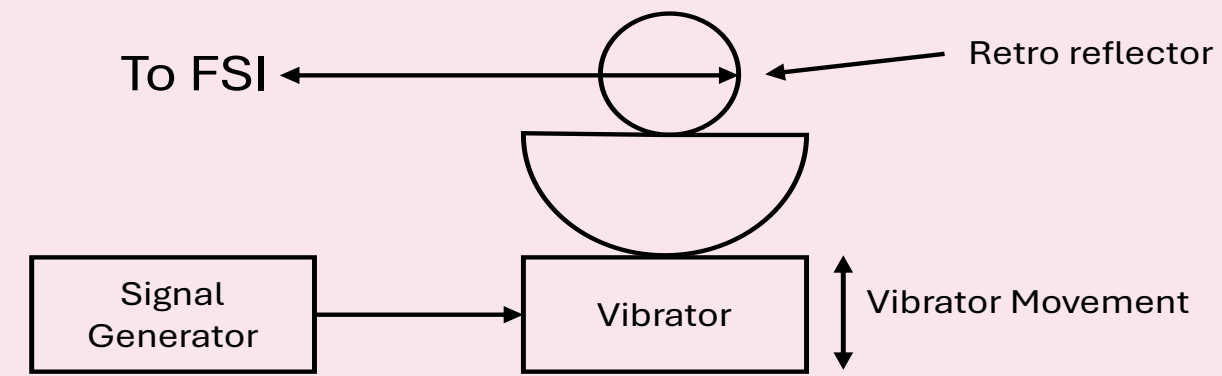
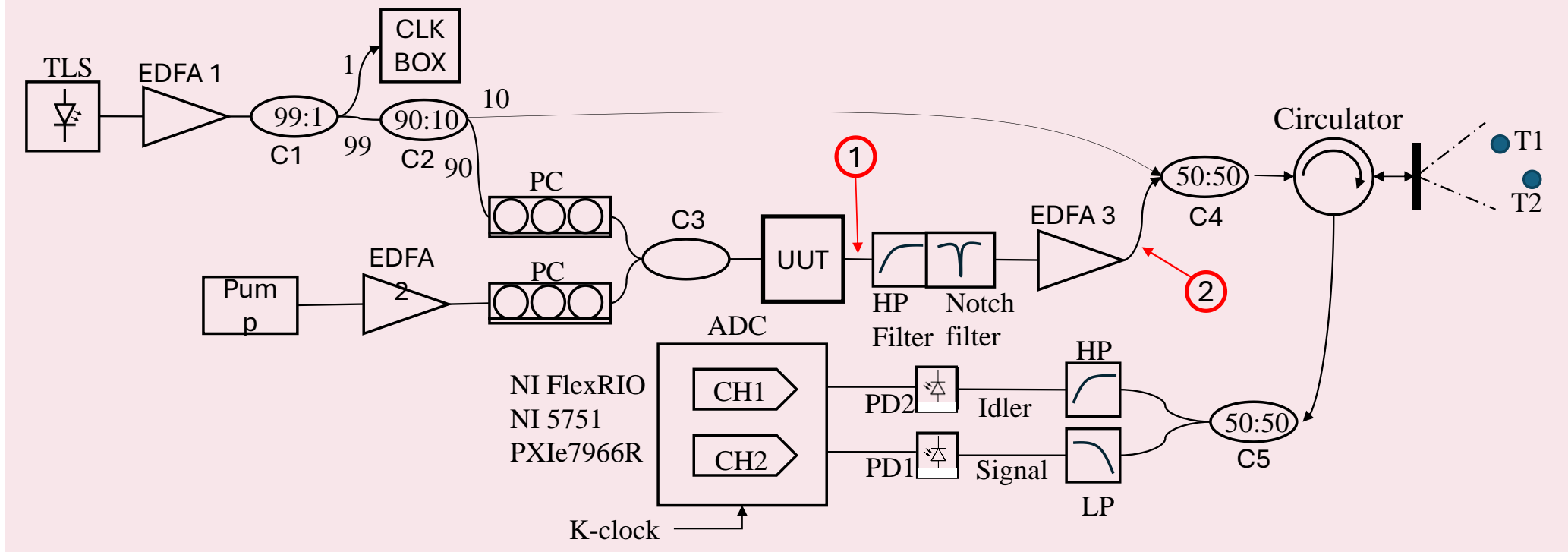

Signal generated by the signal generator stimulate the target movement by changing the OPD of the retro reflector using Elliot piezo vibrator.

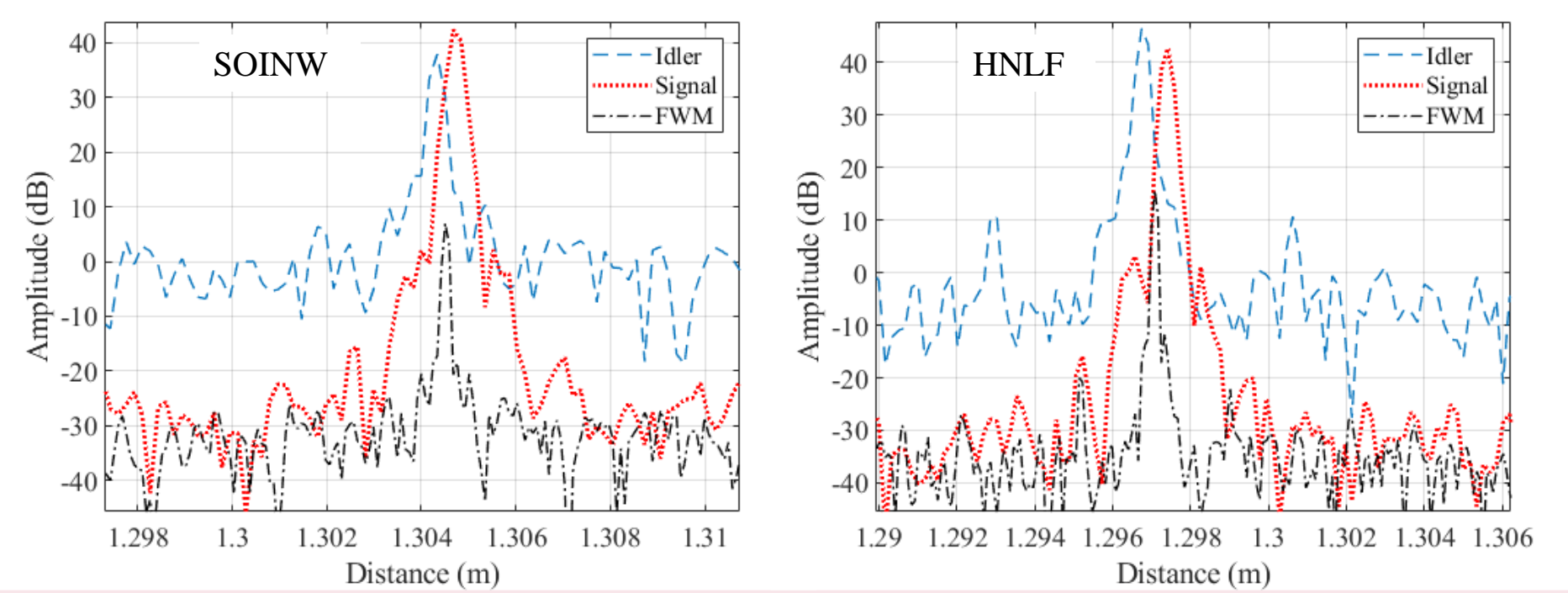

FSI sweep analysis on a vibrating target showing Signal, Idler and FWM

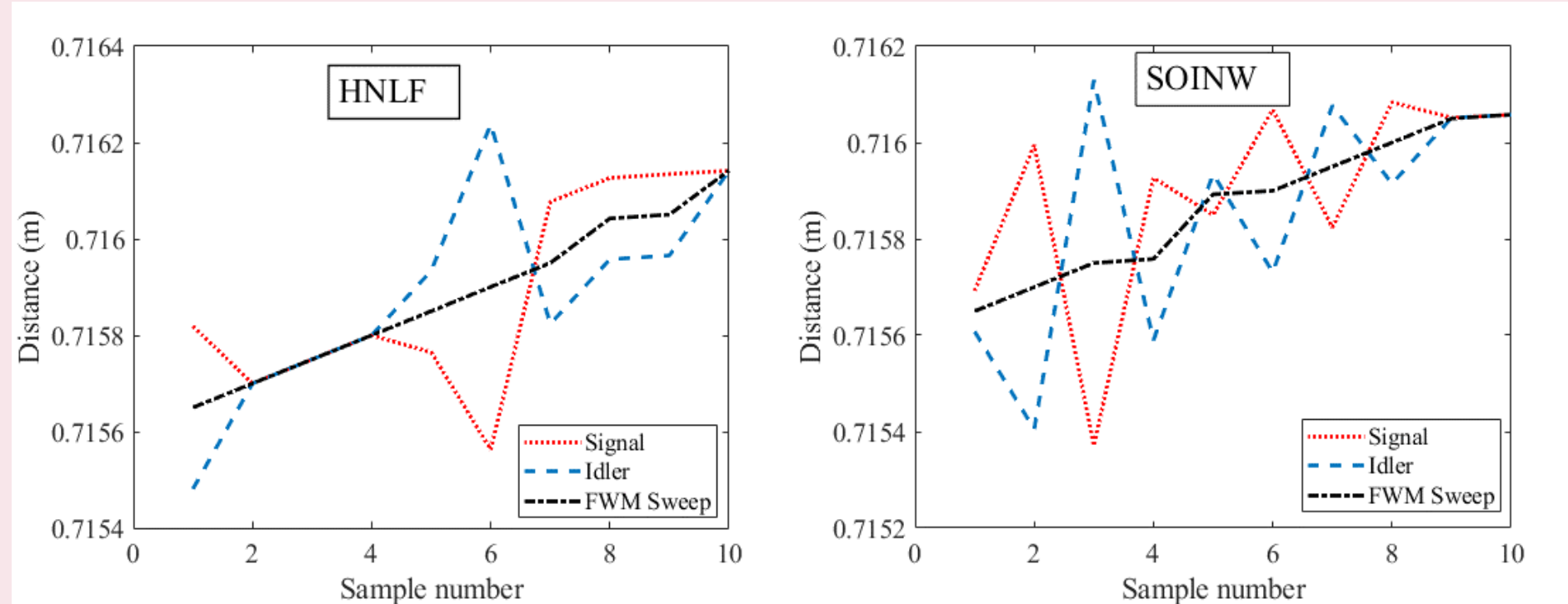

Distance estimation vs obtained samples on a vibrating target.

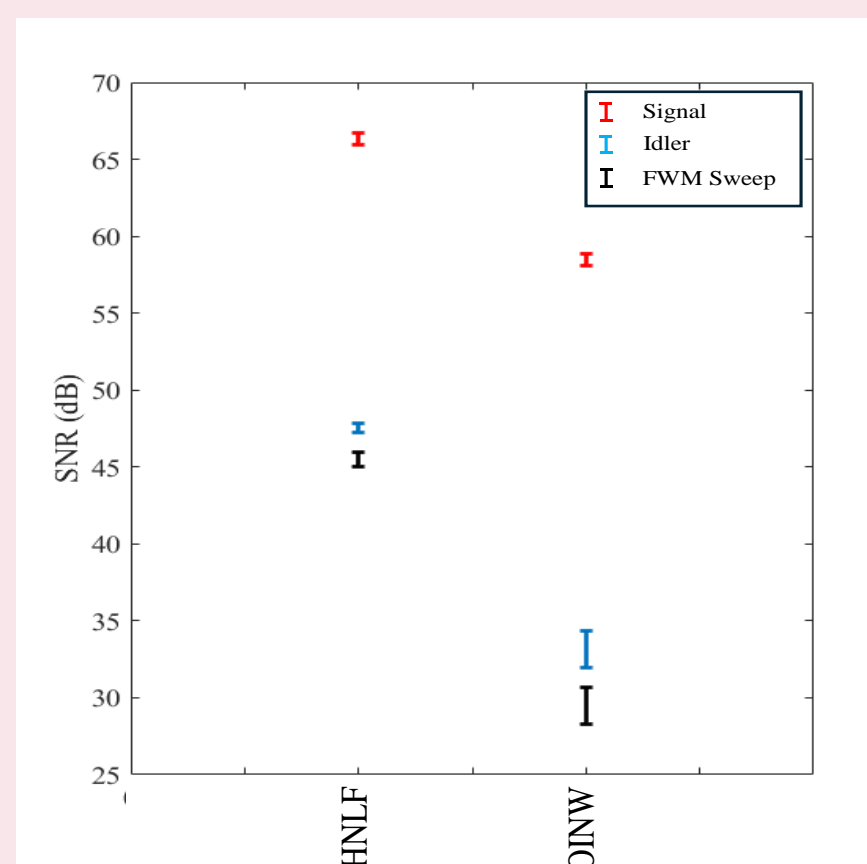

The error chart showing the dual sweep SNR performance

	SOINW (dB)	HNLF (dB)
Signal	0.3934	0.3697
Idler	1.1758	0.2826
FWM Sweep	1.1792	0.4549

SNR standard deviations of FSI Signal, Idler and FWM

	SOINW (dB)	HNLF (dB)
Signal	58.45	66.32
Idler	33.16	47.55
FWM Sweep	29.47	45.497

Measured mean SNR of FSI Signal, Idler and FWM

## Conclusions

- SNR of the generated FWM for HNLF and SOINW is compared. We also present the compared optical power spectrum of the Signal and the Idler of the FWM between the optical band of 1530 nm-1545 nm and 1545 nm -1560 nm.
- We have explained the typical experimental configuration to test both FWM generation techniques, keeping most of the experimental configuration's constant apart from the Unit Under Test (UUT).
- All systems are configured to measure long-range simultaneous absolute distance measurement using the FSI system.

## Key reference

<sup>†</sup> Martinez, J.J., Copner, N.J., Warden, M.S., Hughes, E.B. and Campbell, M.A., NPL Management Ltd, 2019. *Dual laser frequency sweep interferometry system and method*. U.S. Patent 10,168,137.