

Dr. Michael Stepputat, Dr. Markus Meißner

VOLUMETRIC POSITIONING SYSTEM VPS

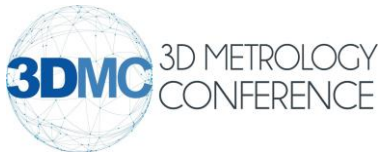

16 – 18 September 2025
Aachen, Germany

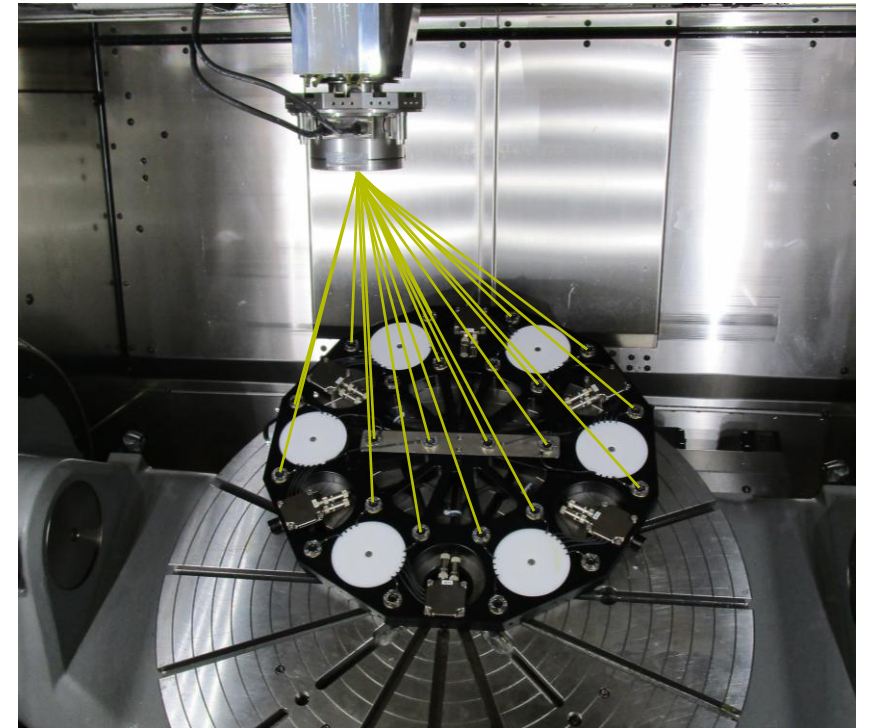

 Public  Internal  Confidential  Strictly Confidential

© DR. JOHANNES HEIDENHAIN GmbH

HEIDENHAIN

VPS: Volumetric Positioning System

HEIDENHAIN

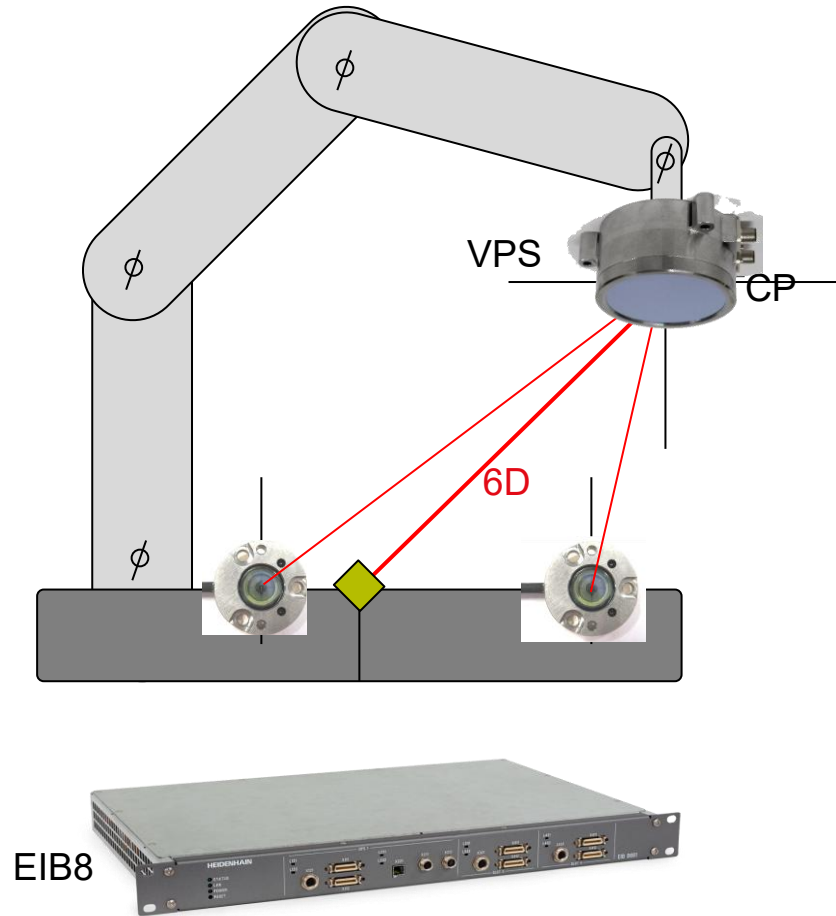

Direct 6D Metrology

- 6D pose of Tool Center Point (TCP)
- Pose with respect to working table
- Bypass of serial kinematics
- Achievement of spatial accuracy
- High sampling rate

Potential Applications

- Machine calibration
- Integration in control loop

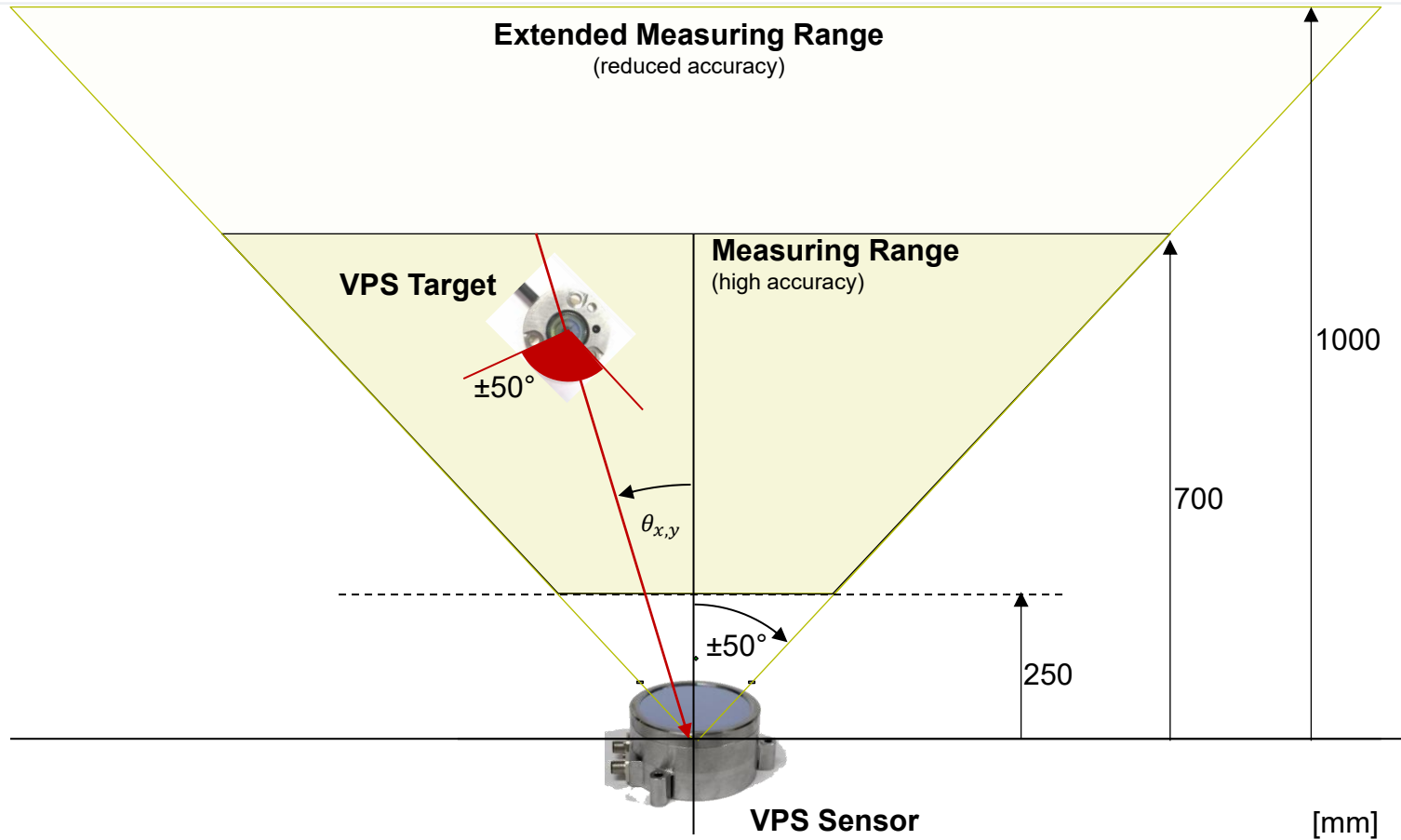

Angular Measurement

- Measurement: 2 angles, incremental
- Angular uncertainty: $\pm 5 \mu\text{m/m}$
- Sampling rate: 10 kHz

Accurate Range:

- Distance to target: 250 mm – 700 mm
- Reception angle: $\pm 50^\circ$
- Emission angle: $\pm 50^\circ$

VPS: Pose Measurement

HEIDENHAIN

VPS Sensor at TCP

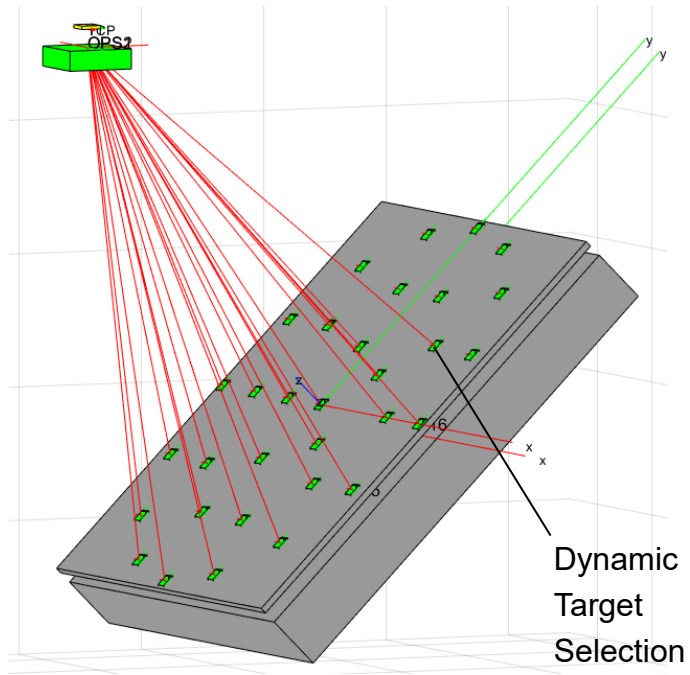

VPS Targets at TCP

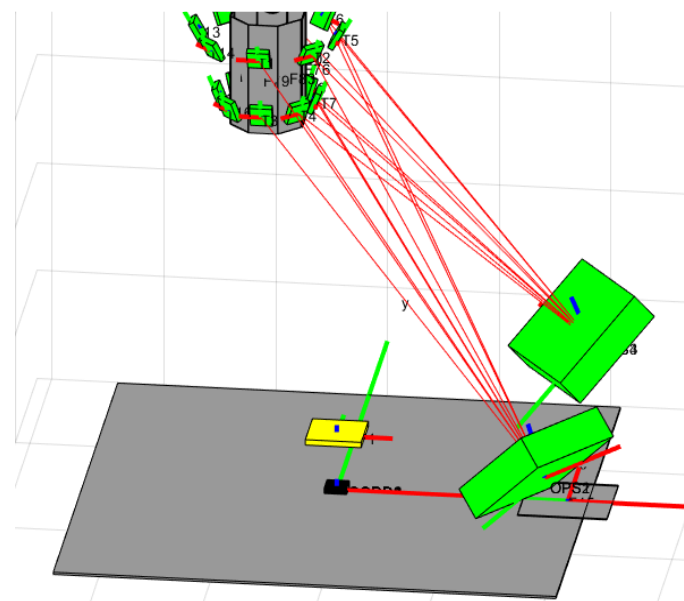

Position Resolution

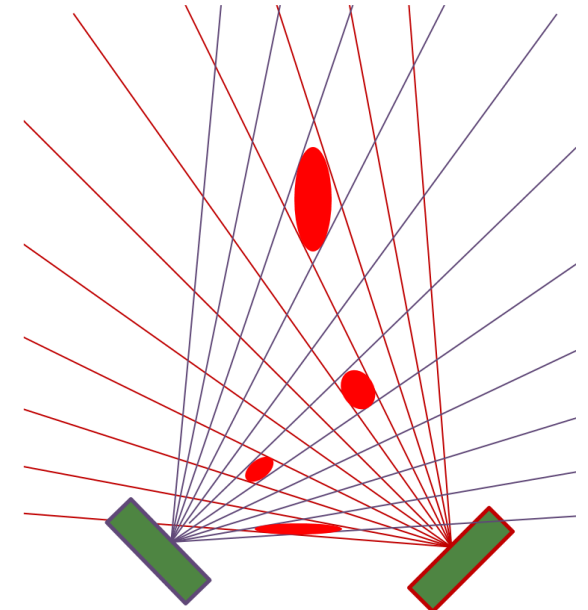

VPS for Machine Calibration

HEIDENHAIN

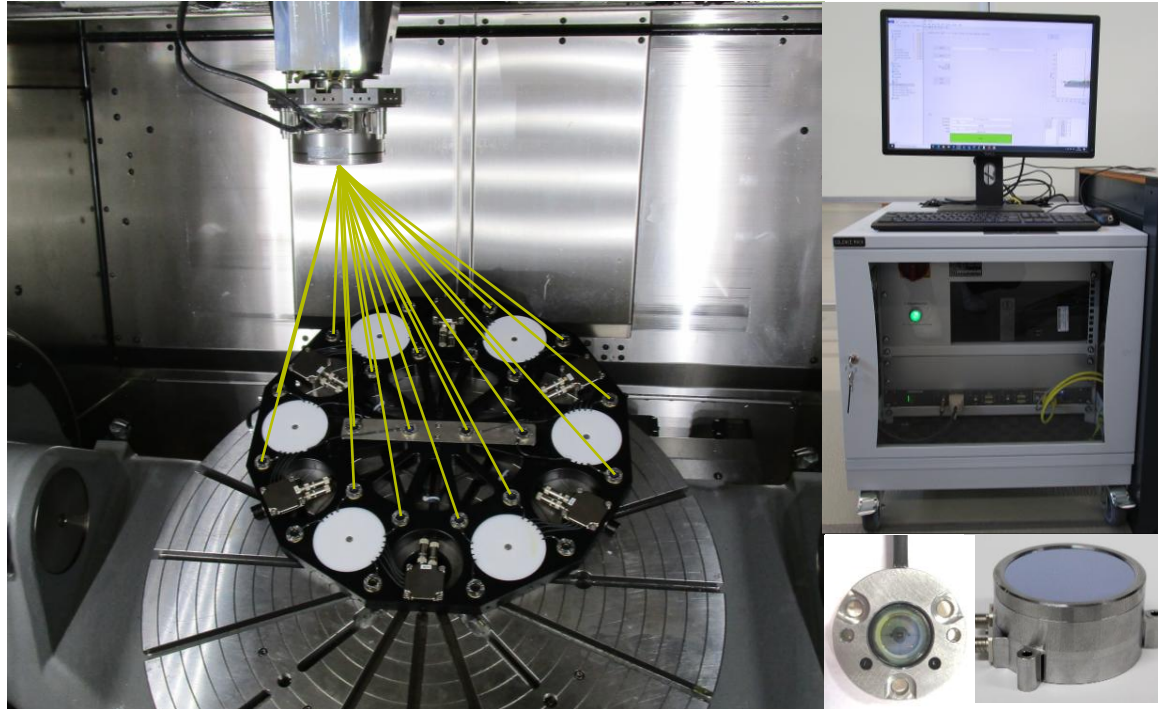

- VPS sensor in spindle
- VPS targets on working table (24 targets, Invar artefact)
- Electronics rack (EIB8, PC)

Position uncertainty at reference machine: $\pm 5 \mu\text{m}$

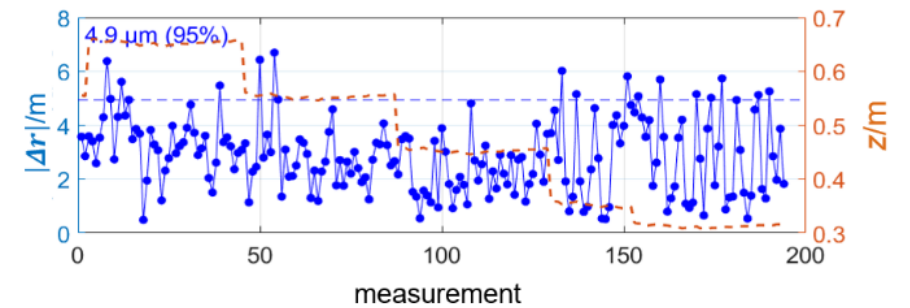
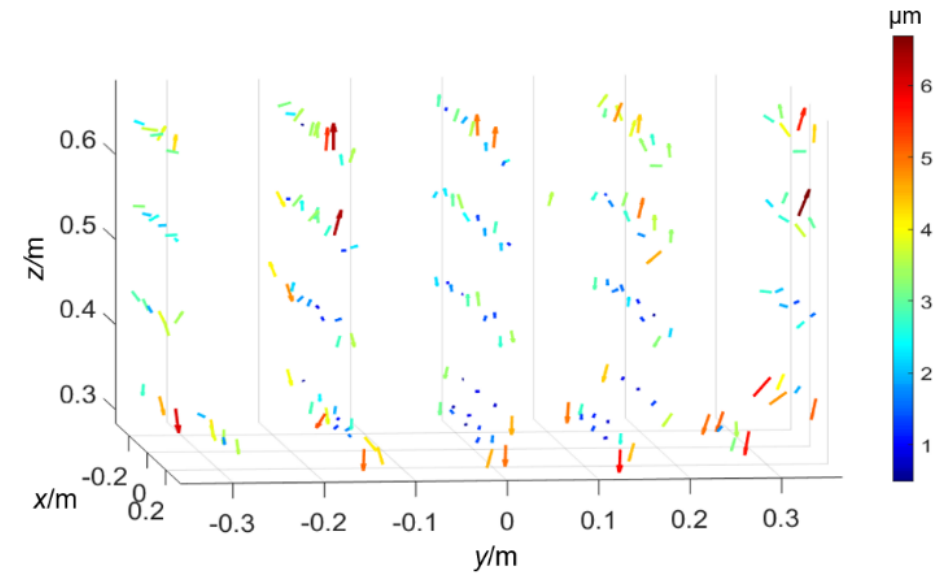

VPS Accuracy at the Shop Floor

HEIDENHAIN

Interferometer

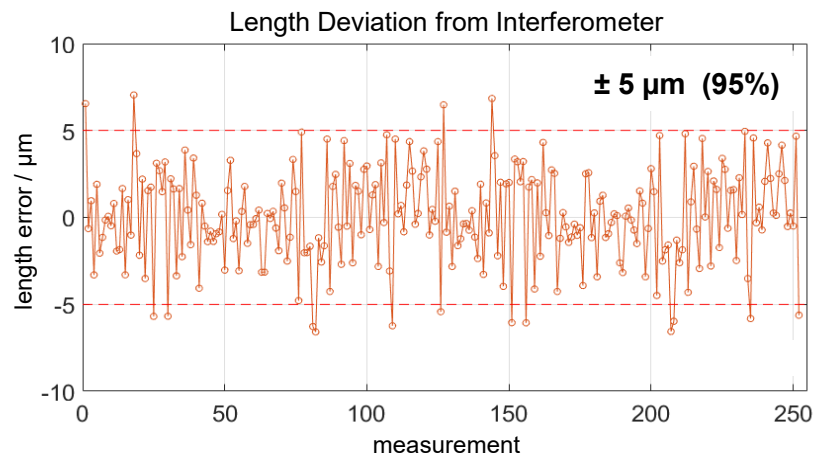
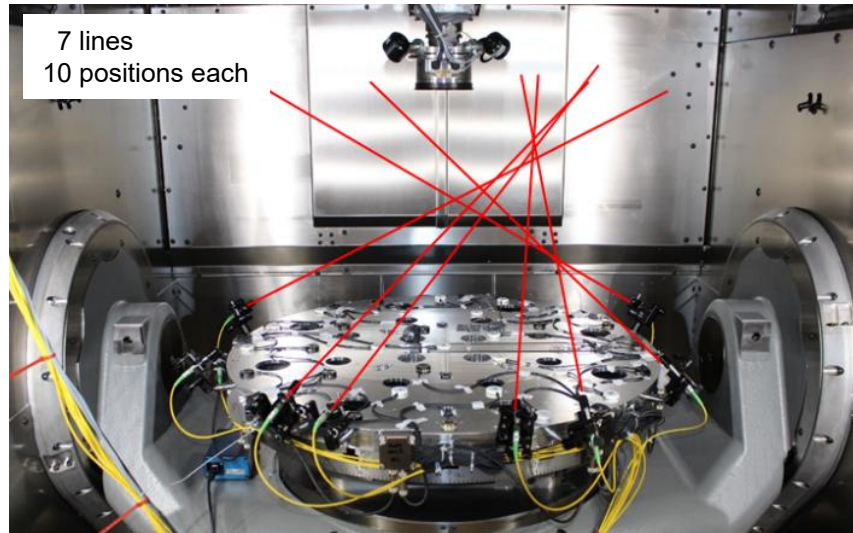

HEIDENHAIN KGM

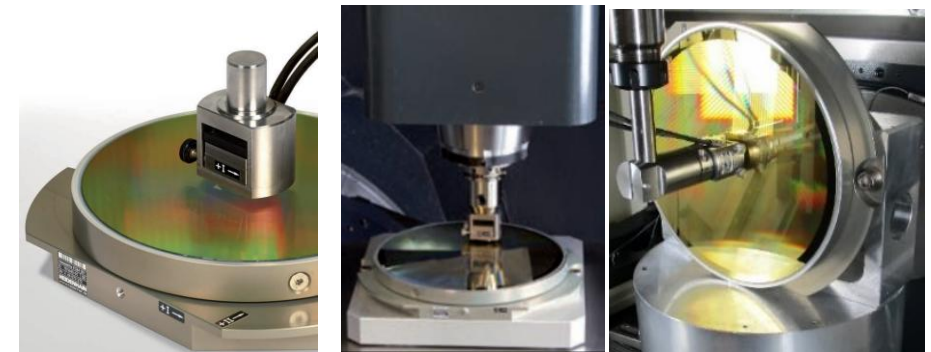
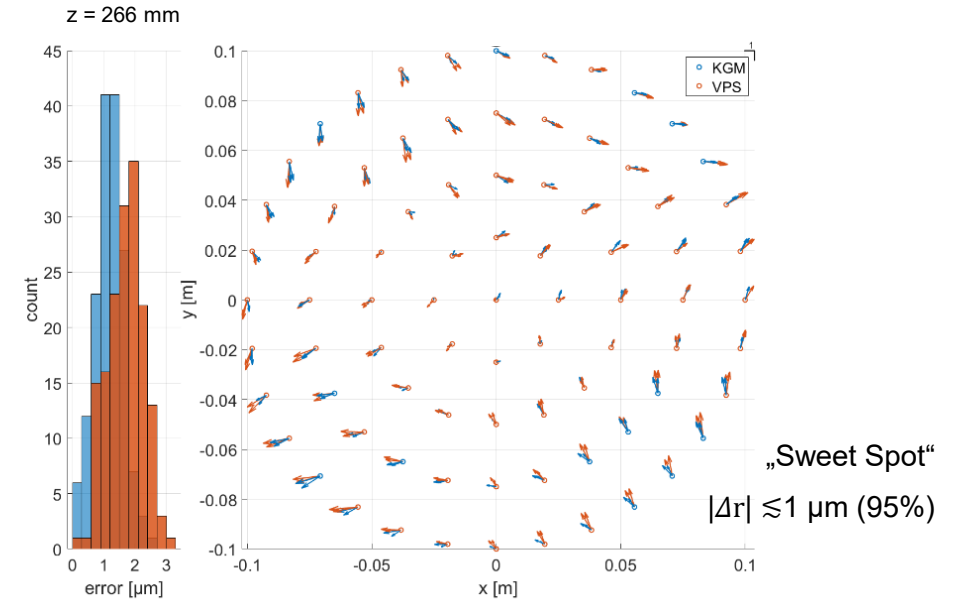

Mounting of VPS



Setup

- VPS sensor at HSK
- VPS target plate on working table
- Cabling: 2x sensor, 1x plate

Calibration

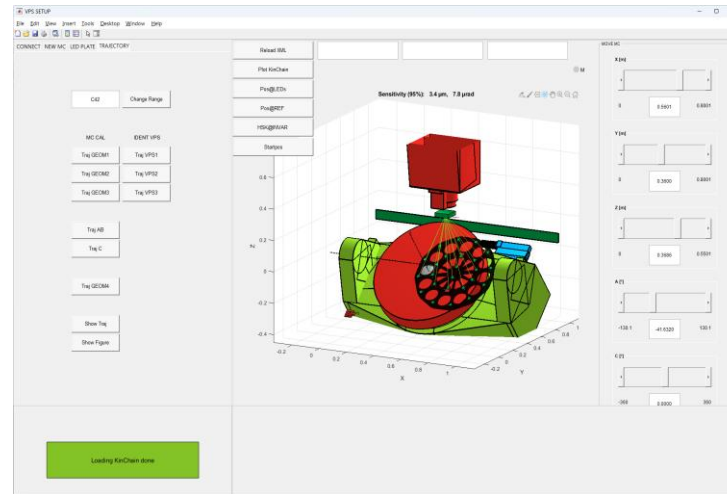

VPS Software

- Kinematics chain download from TNC
- Generation of calibration trajectories
- Automatic calibration measurement
- Generation of calibration table
- Realtime measurement (10 kHz)

Upload to TNC



Upload

- Upload of calibration table
- Confirm on TNC

VPS Calibration Measurement

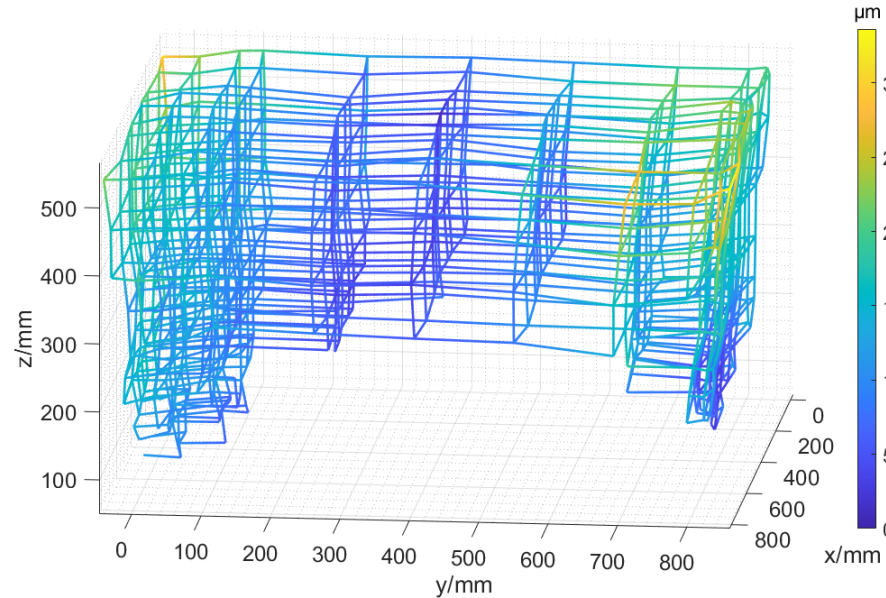

- 800 – 900 machine positions (standstill)
- 8 table orientations (A,C)
- Range extension in Z via $A \pm 30^\circ$
- Stitched into common orientation ($A=0^\circ, C=0^\circ$)
- 45 min

VPS Calibration Table

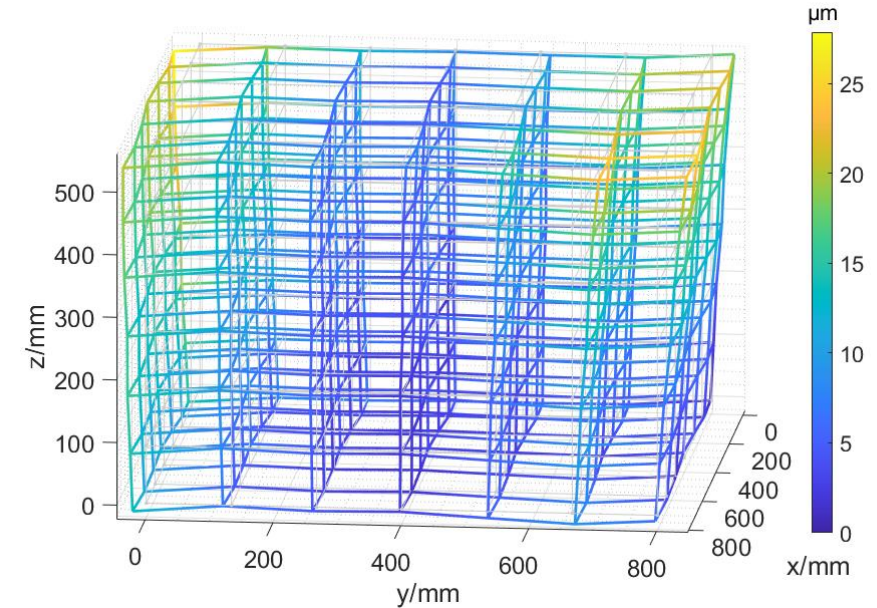

- Rigid Body / Extended Rigid Body / Volumetric Model
- KinematicsComp Table (6D)
- Ready for TNC

VPS Dynamic Measurement

HEIDENHAIN

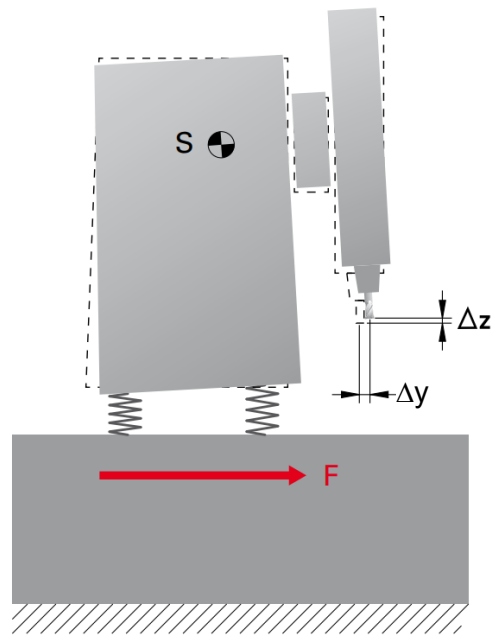

Sampling rate: 10kHz

Resolution (400Hz): $\pm 1 \mu\text{m}$ (95%)

Reproducibility: $\pm 1 \mu\text{m}$ (95%)

Accuracy: $\pm 5 \mu\text{m}$ (95%)

Typical values, dependent on coordinate and measuring position

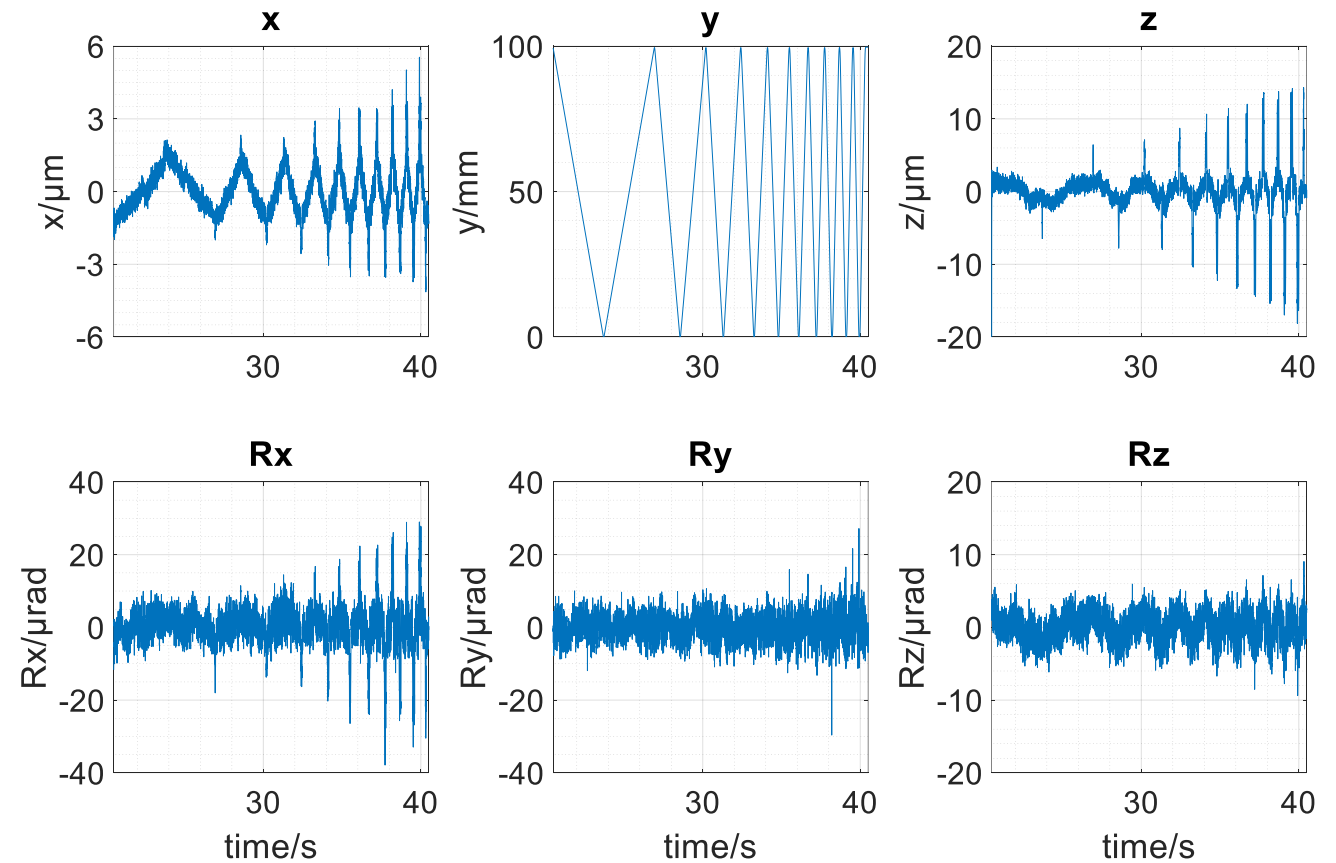

VPS Dynamic Measurement: Crosstalk Compensation (CTC)

HEIDENHAIN

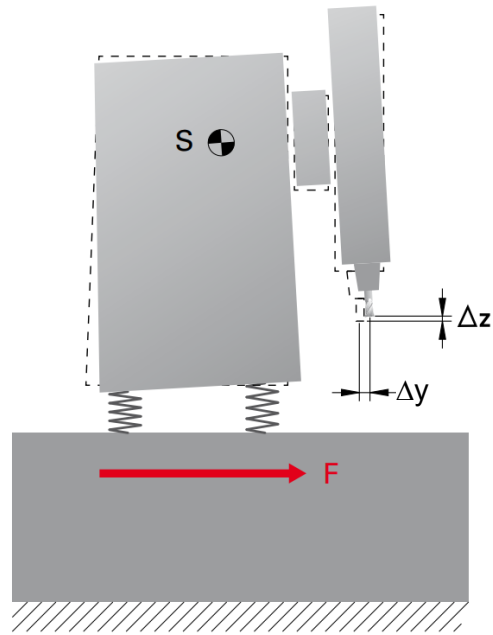

Sampling rate: 10kHz

Resolution (400Hz): $\pm 1 \mu\text{m}$ (95%)

Reproducibility: $\pm 1 \mu\text{m}$ (95%)

Accuracy: $\pm 5 \mu\text{m}$ (95%)

Typical values, dependent on coordinate and measuring position

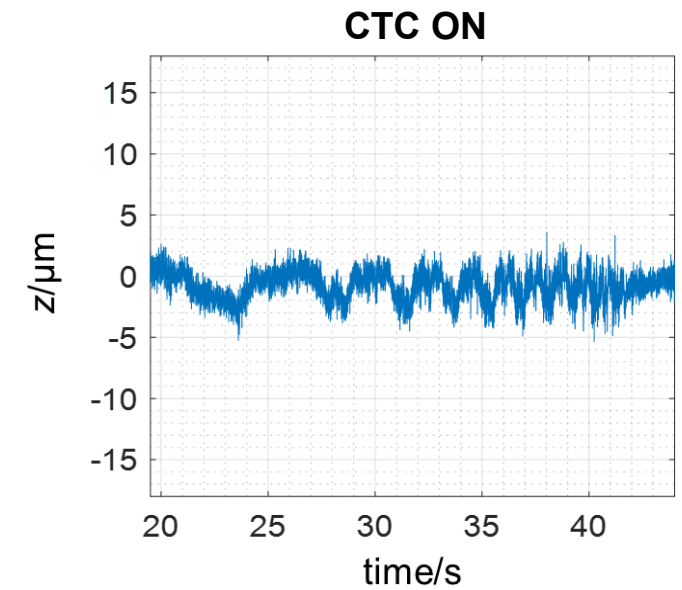
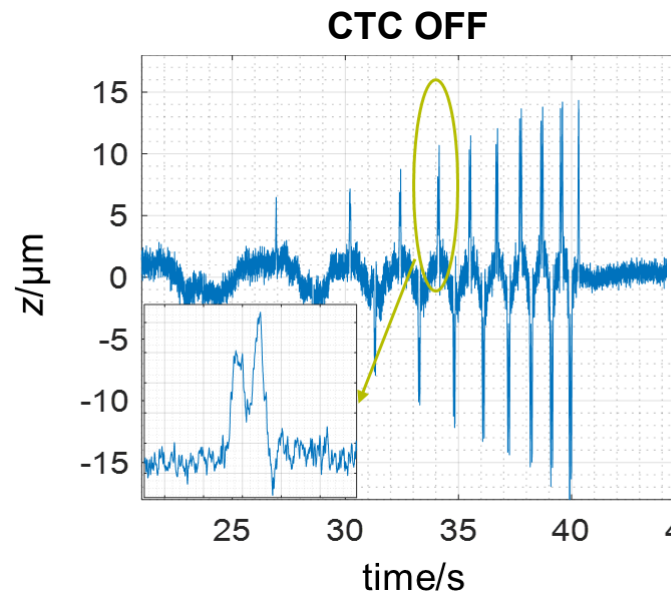

High resolution with high accuracy

Synchronized VPS Measurement

- **Synchronization to TNC**

- TNC triggercard
- VPS synchronized to TNC clock (5 kHz)

- **Position error**

- Axis position: TNCscope
- Spindle pose: VPS
- Calculation: offline

- **Feature**

- 6D position error on user trajectory
- Measurement of inline errors: $\Delta X(X)$

X position error measured during X movement

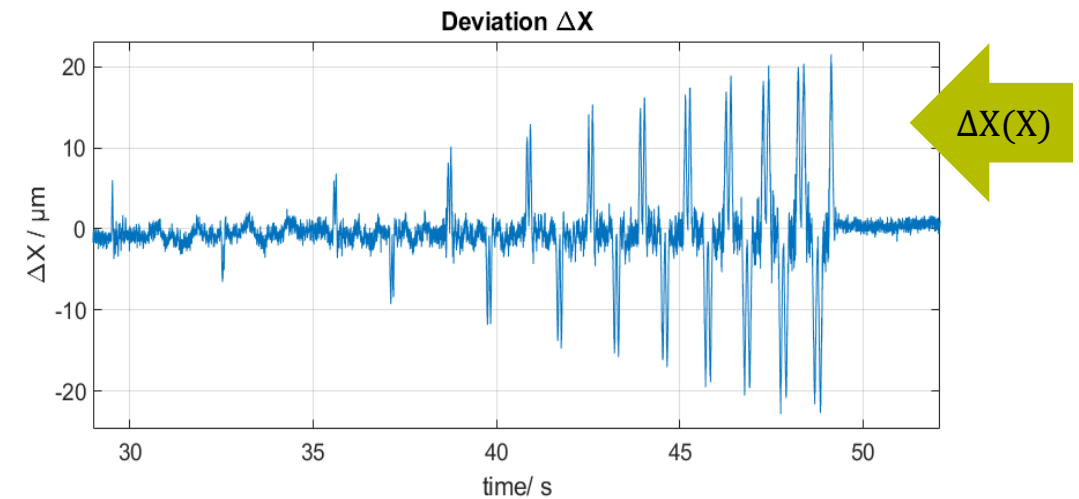
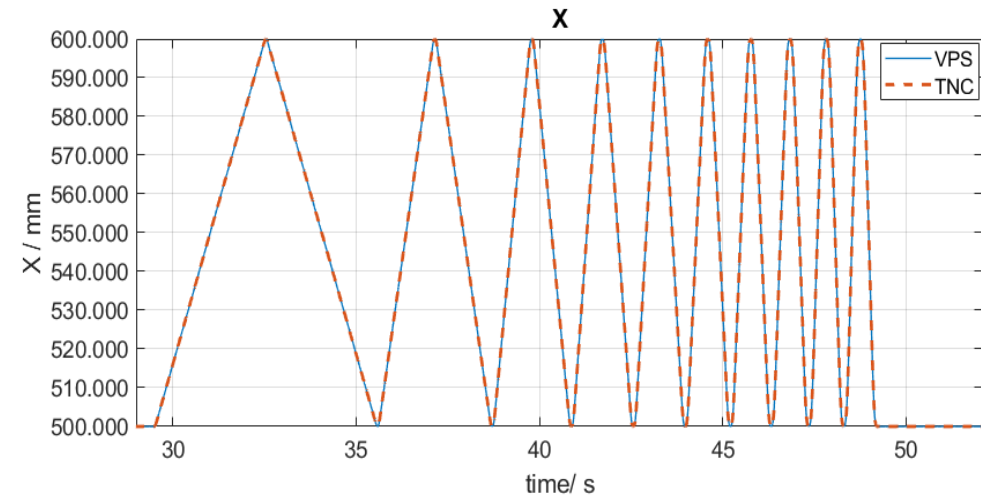

Work in Progress

VPS Applications

HEIDENHAIN

Virtual Metrology Frame

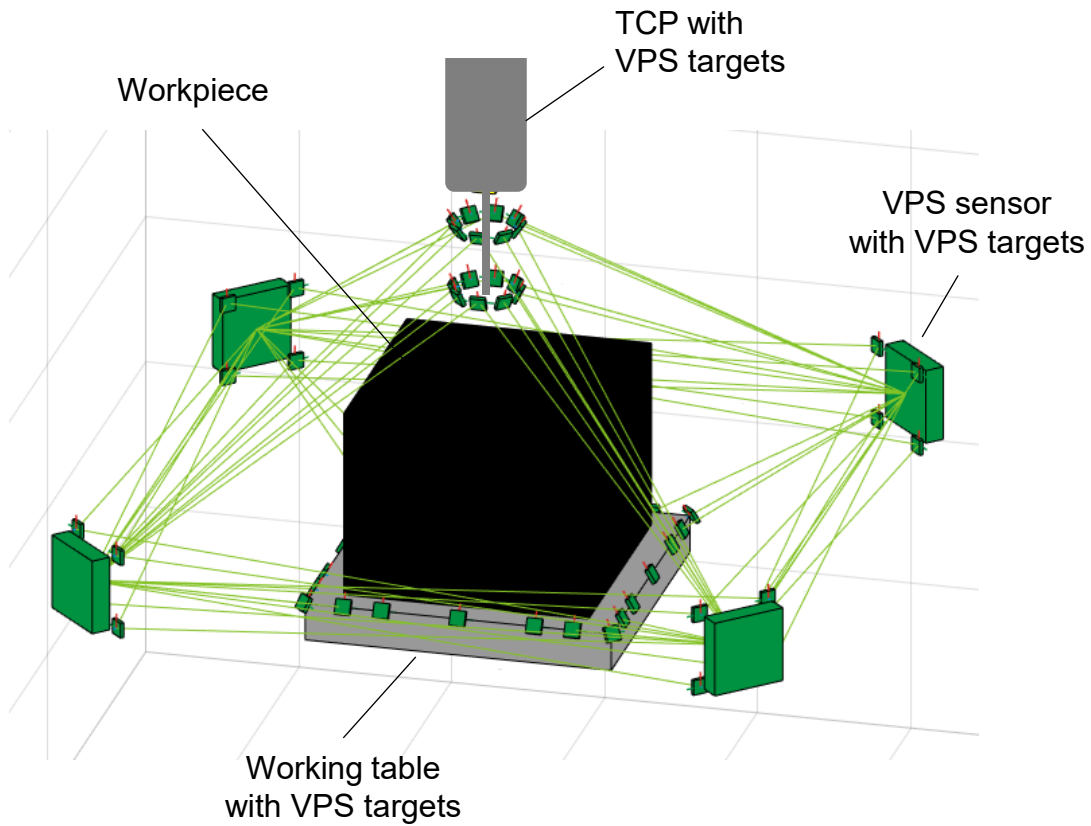

Robotic CMM

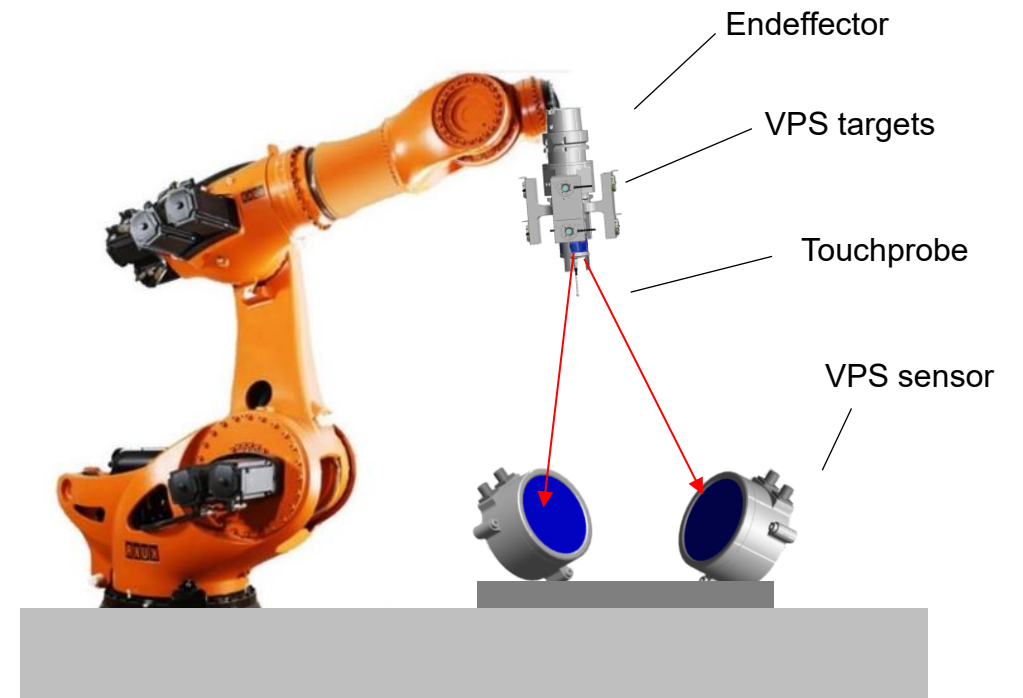

Direct metrology
from working table to tool

**THANK YOU
FOR YOUR ATTENTION !**